

TouchDMIS

Metrology Power with Simplicity

TouchDMIS 7.0 SP2

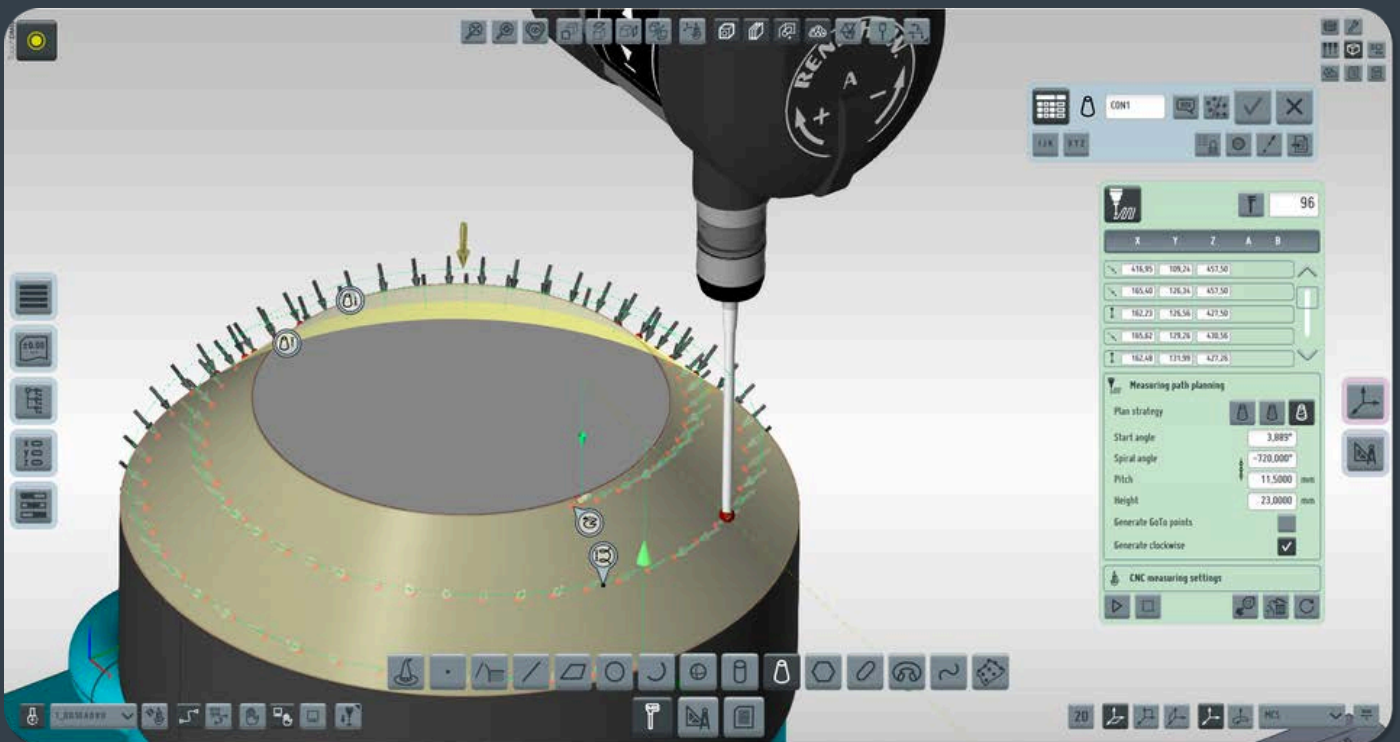

Release notes



7.0.2.135

Date of release:
November 16th, 2022



s.o.l.u.t.i.o.n.s

Summary

 Additional notes	1
 What's new?	2
 Fixed bugs	6

Additional notes

DMIS program with Renishaw PH20 in PCS mode

All DMIS programs with PH20 in PCS mode in versions prior to SP2 will no longer be supported.

From SP2 all programs with the old version will no longer be valid and the user will have to manually edit them.

What's new?

Here's what you can find in TouchDMIS 7.0 SP2

Easy Runner 3.4

EasyRunner 

We add some new features on Easy Runner

- Enabled the project selection in the Program button. Now the user can directly select a program without choosing it from the list

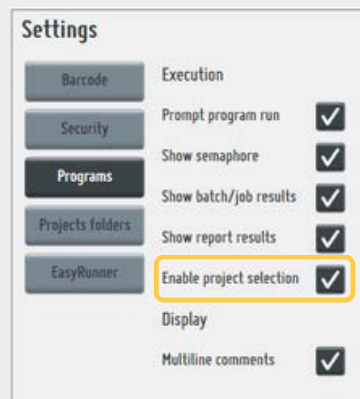

- Automatic project importing from a selected folder

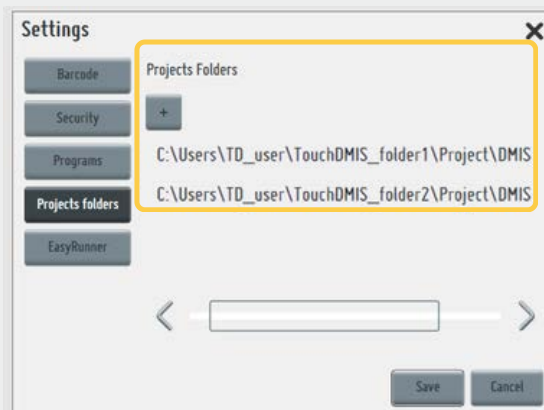

- Improvements and minor fixing in the Barcode input

Select project  | Barcode input  | Scan barcode or input one manually

What's new?

Metrology Gate integration

Now you can enable Metrology Gate data on TouchDMIS. Once connected, you can see real-time metrology room data from the TouchDMIS interface

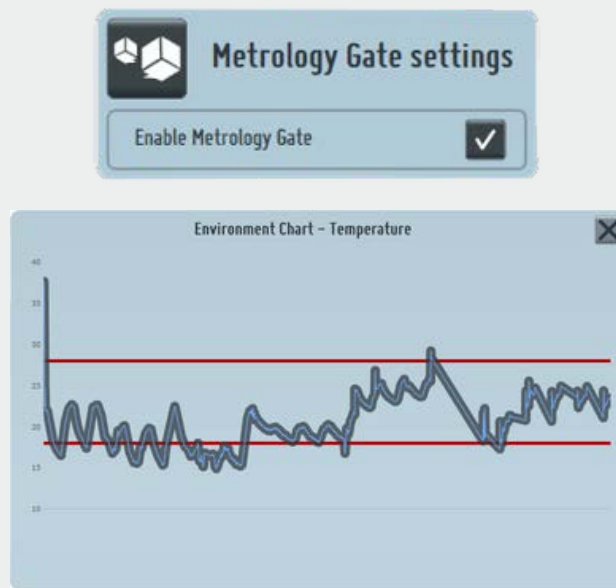

Metrology Gate configuration file shall be saved in:
C:\NMS\TouchDMIS\Settings\MetrologyGate

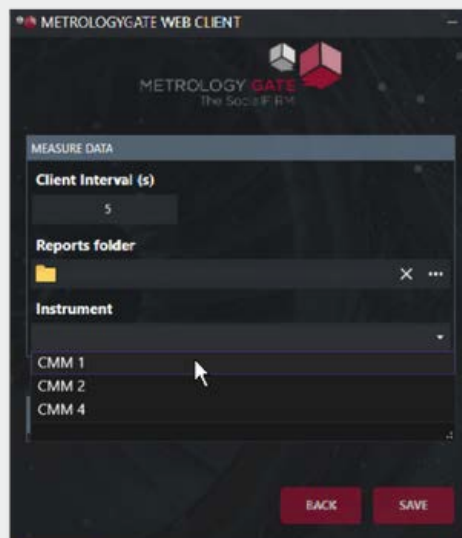

What's new?

PCS improvements

We improve PH20 movement and performance in PCS mode

- Dropped support for PCS with 2 parameters and added support for PCS with 3 parameters
- DMIS syntax changed to create statement with 3 values for PCS
- Added Z_1 , Y and Z_2 on Actual coordinate system window

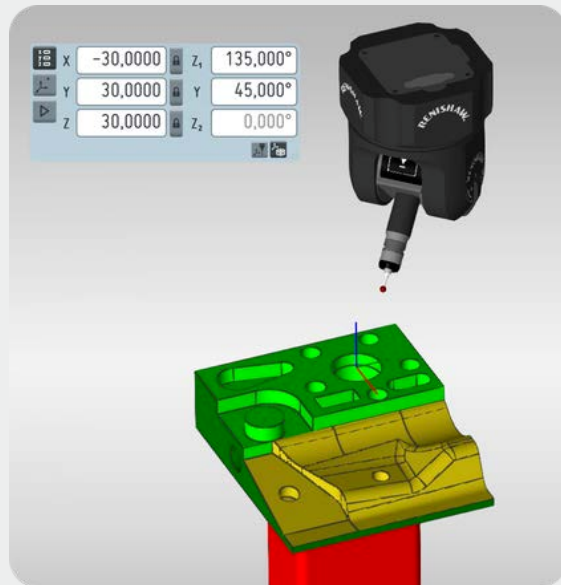
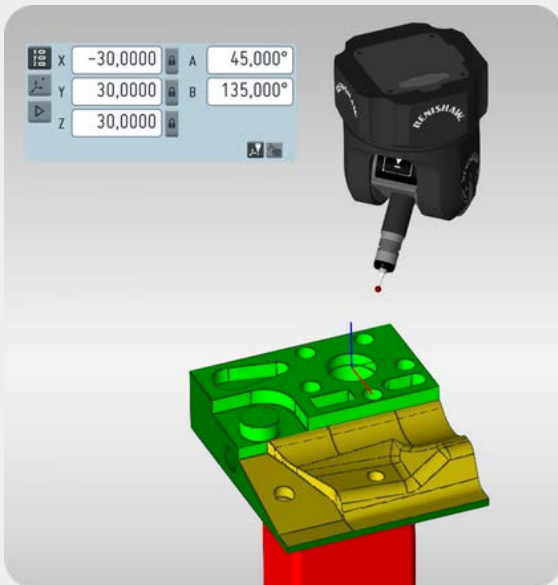

- Added a warning if the program contains old PCS syntax with 2 parameters
- Granted compliancy of execution of third party 5 axis programs
- Deleted the A negative PH20 repositioning in existing programs
- The inclination of the PH20 during the measuring path creation is now synchronized with the actual position of the Ghost probe

What's new?

Release notes and other info

Now you can find the Release notes and other useful information from the TouchDMIS Toolbar.

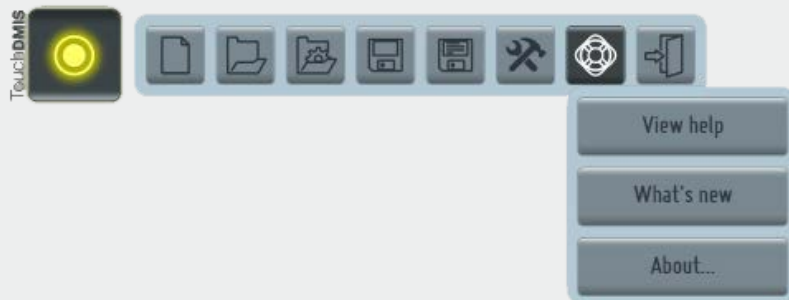

Calibdb backup

Each time the Calib is open, a backup copy will be created. In case of corrupted file, the backup will be restore.

Fixed bugs

TouchDMIS 7.0 SP2

- TD-I2 - Setting machine volume and touching a point does not work
- TD-I4 - Changing probe position without user consent
- TD-I23 - PH20 rotation angles not updated
- TD-I33 - PH20 angular limits
- TD-I41 - CMM model graphic failure
- TD-I42 - The angle written in UI is automatically converted
- TD-I44 - PH20 - Wrong angle conversion
- TD-I46 - PH20 - Wrong behaviour in GoTo panel changing direction
- TD-I50 - PH20 - Wrong value in rotation textbox
- TD-I70 - Positioning message beyond the limits
- TD-I71 - Center model on machine plan does not work
- TD-I103 - Unable to remove saved Preference Systems
- TD-I115 - Activator - Wrong accelerations with GET from CC3
- TD-I161 - Scanning retract to UCC Server
- TD-I165 - Infinite perpendicularity
- TD-I166 - Star probe having problems to be calibrated in "No IPP" mode
- TD-I167 - Changing the point compensation shifts the points measured
- TD-I172 - RD77 - Zero Machine position

- TD-I173 - RD77 - Plane feature compensation
- TD-I175 - Head touch trouble with tiny holes
- TD-I177 - Adding a character in a long program takes same seconds
- TD-I521 - Obtain limits from controller is not working
- TD-I829 - ISO Tolerance hole Ø80-120 J7 uncorrect
- TD-I831 - Upper/lower tolerance swapped
- TD-I849 - CMM Table off value
- TD-I850 - Delete number form GoTo panel
- TD-I858 - Resizing the DRO disappears the coordinates
- TD-I863 - PH20 GoTo in rotation B> +-180°
- TD-I880 - Translation of SettingControl.PointFromCmmTableMsg
- TD-I884 - UCC Machine volume limits
- TD-I896 - GOTO PCS wrong UI
- TD-I899 - Ghost Probe angles
- TD-I901 - Parser does not check for invalid head angles
- TD-I902 - Avoid to change wrong angle with PH20
- TD-I903 - Update GOTO panel UI
- TD-I904 - Unable to load big tools list from UCC Server
- TD-I905 - Wrong syntax for ALLAXIS
- TD-I906 - Changing sensor add a SCNMODE/OFF in DMIS

- TD-I907 - Button disabled during machine configuration with a not setup axis
- TD-I913 - Missing GOTO PCS conversion when changed RS
- TD-I923 - Stops reposing after 10000 UCC commands
- TD-I936 - Fix syntax DECPL/ALL,DEFAULT
- TD-I945 - Correct version number on About page
- TD-I950 - Error during clearance plane
- TD-I958 - Wrong angles teaching
- TD-I961 - Exception trying to calibrate PH20
- TD-I962 - PH20 HEADCS manual measure saves wrong values
- TD-I994 - Impossible to scan an unknown curve feature
- TD-I996 - PH20 changes angles if approach is modified

TouchDMIS

THE MEASURING TOUCH



s.o.l.u.t.i.o.n.s