

# TouchDMIS

THE MEASURING TOUCH



**TouchDMIS 9.0**

**9.0.0.156**

**Date of release:  
June 13th, 2024**

**what's new  
release notes**



s.o.l.u.t.i.o.n.s

# TouchDMIS 9.0

---

 What's new?	1
 What we have improved	14
 Fixed bugs	16
 Supported Hardware & Drivers	20
 PC specifications	21



# Information about this release

---

Our continuous and relentless effort to develop an innovative and always cutting-edge CMM software leads us to the release of TouchDMIS 9.0.

As with TouchDMIS 8.0, we are continuously integrating new controllers and measuring devices into our software, such as the full integration of LK and Renishaw Changer rack. Now you can manage them in TouchDMIS without third-parties support. See in this document the list of updates and Changer racks available.

We also welcome the PMT portable arms, now completely integrated in touch trigger and analogue scanning mode.

Last but not least, the Renishaw Equator Gauging System integration is finalized. See details on the next pages.

In addition, we continue our work to offer a remarkable CMM software user experience, so we have improved the UI and UX in a few areas of the product.

As always, we thank our customers and distributors who constantly provide us with useful feedback for our product development. We would like to inform you that our digital channels are always accessible:

TouchDMIS info & marketing channel

**info@touchdmis.com**

TouchDMIS technical support

**support@touchdmis.com**

The TouchDMIS team



**what's new**



# What's new

## Auto-selection of the tool (TD-I1211)

By selecting the nominal feature, the user can auto-select the optimum orientation to measure the specified feature.

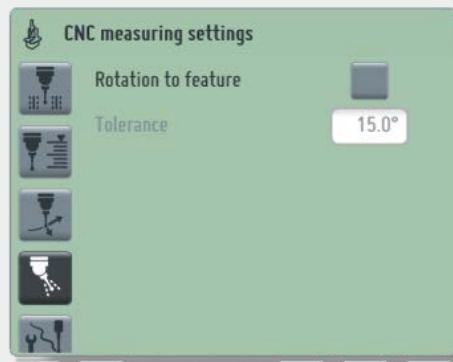

The default tolerance angle is taken by the DMIS template.  
If the Tool does not exist, the nominal one will be proposed.

**tag:** Tool, Probes

## PMT portable arm integration (TD-I1206)

We welcome the PMT range of portable arms.  
Now PMT is integrated in touch trigger and analogue scanning mode in TouchDMIS.

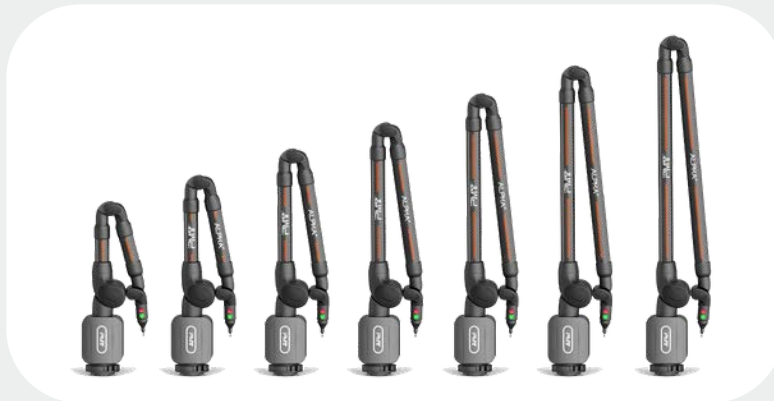

**tag:** Portable Arm, Integration

# What's new

## Changer rack - New models and integration inside TouchDMIS (TD-I1211)

Complete integration of LK and Renishaw Changer rack.

Now you can manage all LK and Renishaw Changer rack directly from TouchDMIS with no need to use third-party external software.

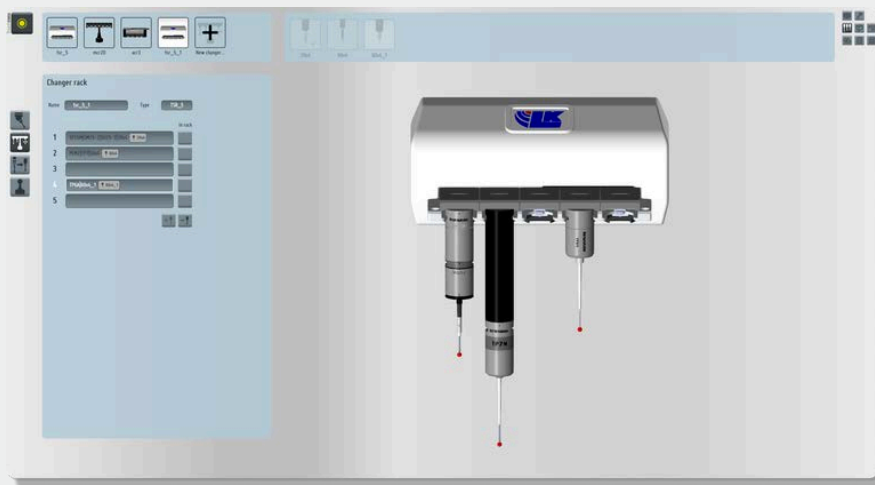

We also improved the Changer rack configuration user experience:

- Added Changer rack definition position
- Added A and B head angles for each docking port
- Offset definition for each docking port
- Possibility to add customized approach and retract
- Added Clearance extra distance definition

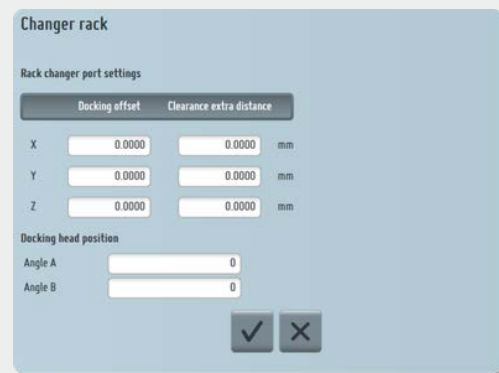
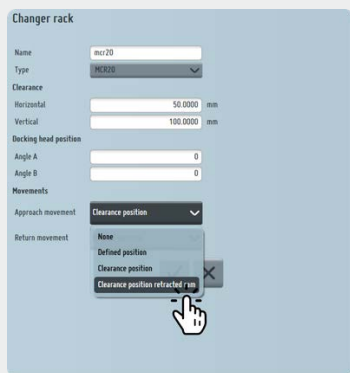

tag: Changer rack

# What's new

- Added Changer rack component visualization

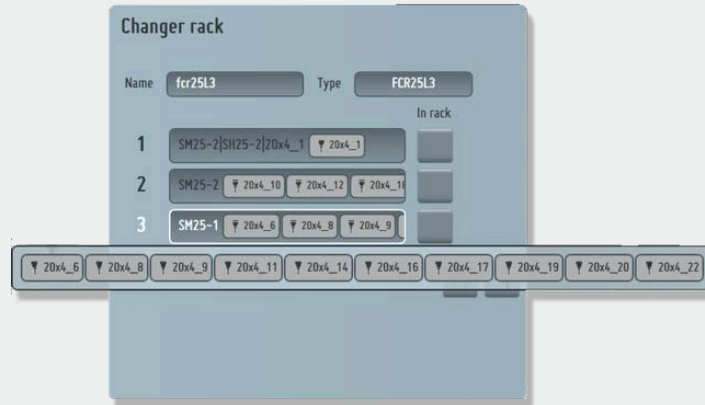

We added the possibility to handle multiple racks simultaneously.



And we have improved the graphical model of all changer racks and more realistic design of calibration spheres.

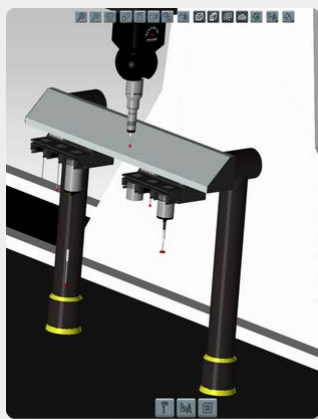

tag: Changer rack

# What's new

Here is a list of the new Changer rack:

## LK series

**MSR20-3**

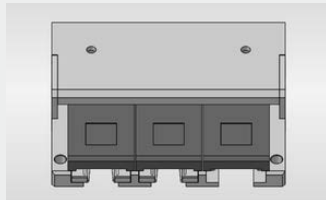

**MSR25**



**TSR-5**

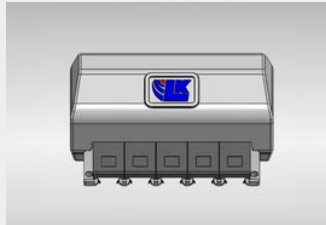

**TSR-10**

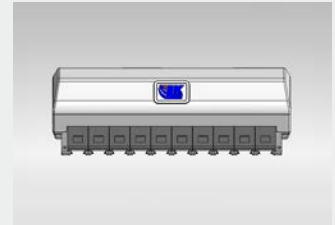

**SSR25-3**

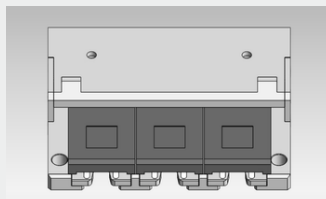

**MSR200-3**

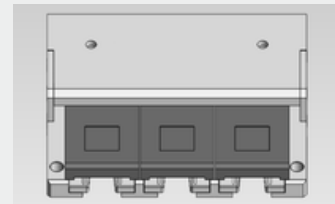

## Renishaw series

**FCR25**

FCR-25L3  
FCR-25L6  
FCR-25TC



**SCR200**

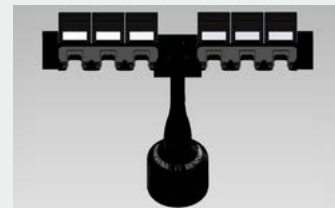

**MCR20**

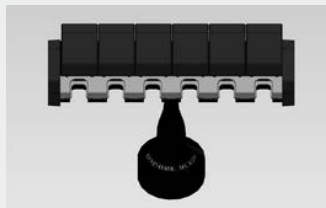

**ACR3**



# What's new

## Incremental GoTo panel (TD-I1371)

We have added a support for incremental GoTo.

Now you can set incremental GoTo's easily directly from the Actual coordinates window.



You can select Incremental GoTo by right-click or tapping and press hold the GoTo button on the Actual coordinate window.

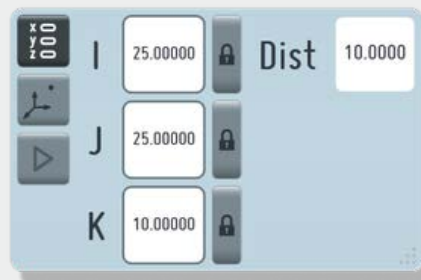

Like simple GoTo, you can input incremental GoTo's and press play to execute the operation.

Optionally, from the settings you can enable the display of delta GoTo dialog box.

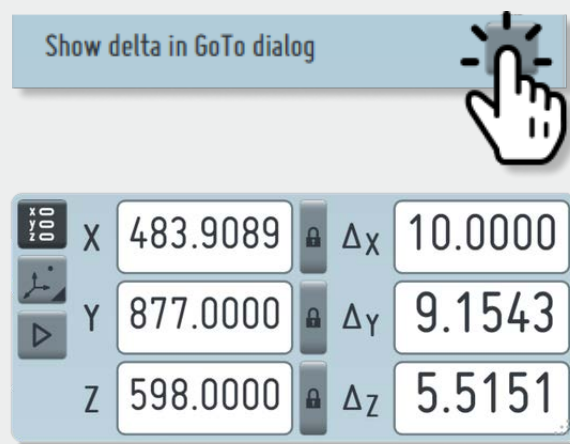

tag: GoTo

# What's new

## Renishaw Equator™ integration

(TD-I1126 - TD-I1127 - TD-I1128 - TD-I1251 - TD-I1252 - TD-I1254)

We finalized the integration of the Renishaw Equator Gauging System within TouchDMIS started with version 8.0.

Now you can select “Equator” as CMM model, fixed some issues in the Machine setup configuration, and added Master and Measure program status.



tag: Renishaw Equator

## SP25 scanning integration with Deva CNC (TD-I1285)

We have integrated the scanning using Renishaw SP25 with Deva CNC.



tag: SP25

## Translation language update

We have improved translation for all the supported languages, including new technical and local translations.

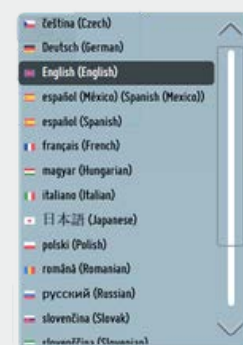

tag: Translation

# What's new

## Graphical Simulator (TD-I1275 - TD-I1286)

We have improved the Graphical Simulator for offline programming.

Now you can find a new panel that allows you to edit simulation speed and random error. You can find it in the left-bottom toolbar (CMM Status Toolbar)

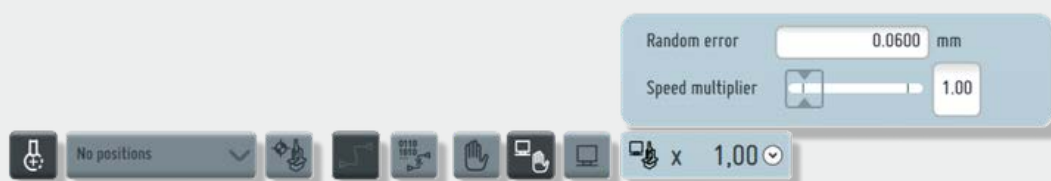

Using MAN mode, by selecting the Measure option you can simulate manual point.

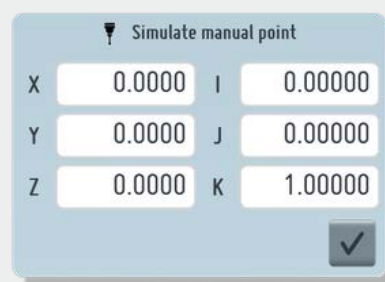

**tag:** Graphical Simulator

## Surfacer SDK Roughness Sensor

Starting from TouchDMIS 8.0 release, we are further integrating the Surfacer SDK roughness sensor series.

Surfacer SDK using TouchDMIS provides surface profile measurement data on a range of material types.

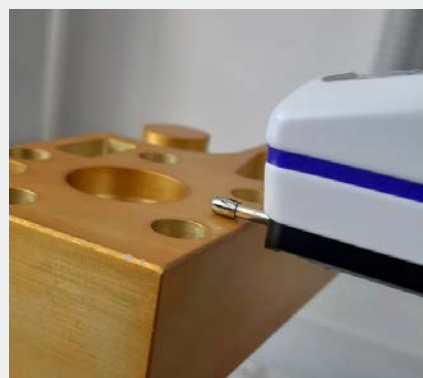

**tag:** Roughness sensors

# What's new

## Gear measurement implementation (TD-I1392)

The gear inspection module is implemented inside TouchDMIS using external evaluation.

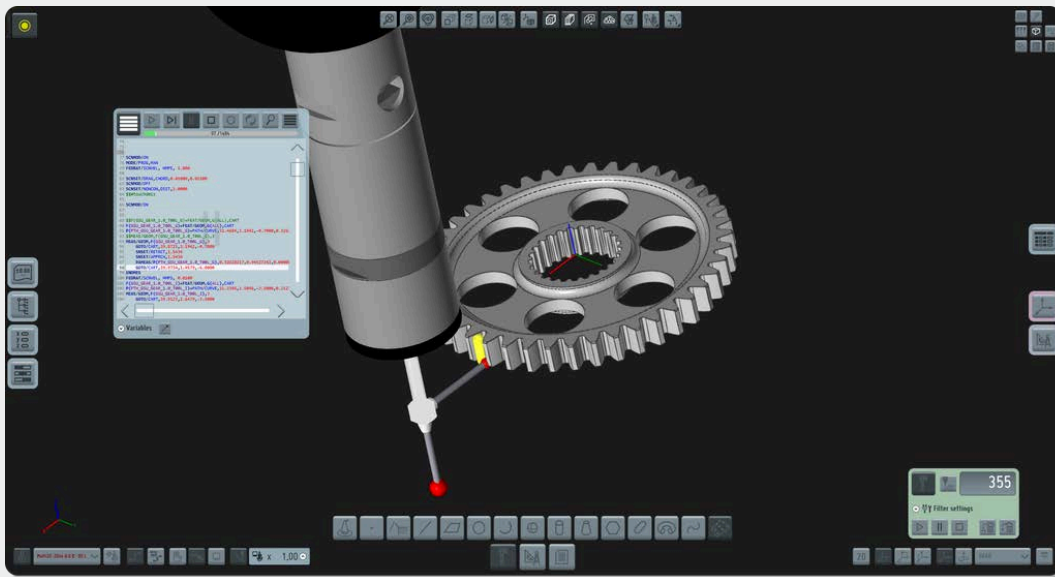

tag: Gear Measurement

## Hotkey implementation (TD-I1393)

We have integrated hotkey integration for DMIS editor.

Open the DMIS editor and manage execution with simple shortcuts.

**F5 = Program Play**

**F4 = Program Stop**

**F8 = Play Step-by-Step**



tag: DMIS

# What's new

## Jump Alignment (TD-I1372)

A new implementation of the Jump alignment (“Leap frog”) is done.

Jump alignment is used to move part or the inspection system one or more times allowing user to inspect part that is much larger inspection system working volume.

This new implementation opens the possibility to handle multiple arms and instruments.

You can enable Jump alignment through Settings > Machine > Jump (leap frog) alignment

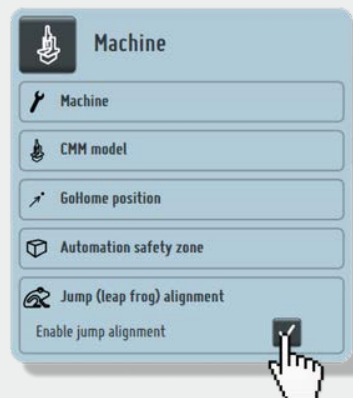

Once enabled, you can define jump alignment from the Measuring port.



tag: Alignment

# What's new

## API tracker V-Probe II integration (TD-I1428)

Implemented the new API tracker using the V-PROBE II.



tag: API tracker, Integration

## TESA Reflex retrofit kit (TD-I1417)

Integration of a counting card that interfaces automatically the TESA Reflex CMM using a serial line.

Board name is **IMUSB-100MH** from Insight Metrology.



tag: TESA, Integration

## Message in report when nominal tool is used to measure a feature (TD-I1418)

If you measure a feature with a nominal probe, TouchDMIS alerts you in the tabulated report.

	Actual	Nominal	High/Zone	Low/Bonus	Deviation	Error	Graph
<b>Feature actual measured with nominal probe!</b>							
Plane FA(PLN1)							
X	-8.3333	2.5000			-10.8333		⚙ CAD1 mm, dec
Y	-5.0000	-25.0000			20.0000		
Z	0.0000	0.0000			0.0000		
I	0.00000	0.00000			0.00000		
J	0.00000	0.00000			0.00000		
K	1.00000	1.00000			0.00000		
D	0.0000						

tag: Report

# What's new

## New protected Error Map (TD-I1429)

Improved geometrical error map using a reliable and well-proven mapping solution that covers:

- Bridge CMMs with different kinematics
- Horizontal CMMs with column correction
- Dual reading linearization

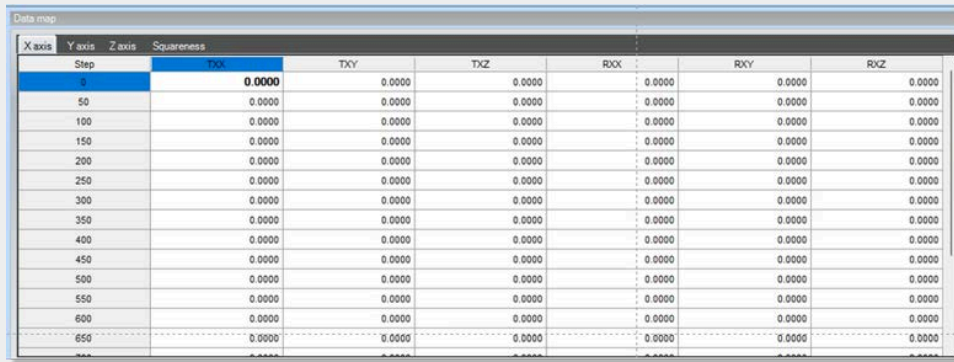

Step	TX	TXZ	RXX	RXY	RXZ
0	0.0000	0.0000	0.0000	0.0000	0.0000
50	0.0000	0.0000	0.0000	0.0000	0.0000
100	0.0000	0.0000	0.0000	0.0000	0.0000
150	0.0000	0.0000	0.0000	0.0000	0.0000
200	0.0000	0.0000	0.0000	0.0000	0.0000
250	0.0000	0.0000	0.0000	0.0000	0.0000
300	0.0000	0.0000	0.0000	0.0000	0.0000
350	0.0000	0.0000	0.0000	0.0000	0.0000
400	0.0000	0.0000	0.0000	0.0000	0.0000
450	0.0000	0.0000	0.0000	0.0000	0.0000
500	0.0000	0.0000	0.0000	0.0000	0.0000
550	0.0000	0.0000	0.0000	0.0000	0.0000
600	0.0000	0.0000	0.0000	0.0000	0.0000
650	0.0000	0.0000	0.0000	0.0000	0.0000

tag: Error map

## Automation Process Interaction (TD-I1421)

A set of automation commands are available to interact with I/O card I/O controller. Using a configuration file it is possible to interact:

- Bridge CMMs with different kinematics
- Horizontal CMMs with column correction
- Dual reading linearization

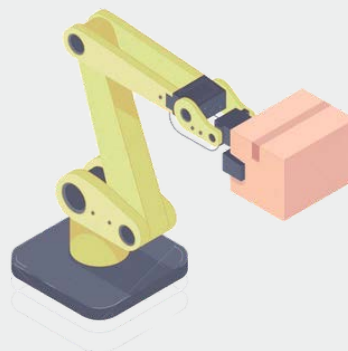

tag: Automation

# What's new

## Thermal compensation for CMM and Part (TD-I1422)

We split up thermal compensation for CMM and Part.

Now you can set thermal compensation from both directly from the TouchDMIS main interface.



tag: Thermal compensation

## Calibration routine changes (TD-I1423)

Now the calibration routine returns always above the calibration sphere so the "Move over sphere" option is deprecated.



tag: Calibration

# What's new

## New 5.0 Plugin functionality (TD-I1430)

Using the new 5.0 Plugin interface **IsActivable()**, you can decide whether the plugin will be launched and shown on each session opening or whether the plugin will be installed in a menu button and called when required.



tag: Plugin

## Machine Setup UI-UX improvements (TD-I1377)

We have improved the Machine Setup UI and UX based on different types of CMM and Controllers.



tag: Machine Setup

## Algorithm certification by Physikalisch-Technische Bundesanstalt

Our algorithm have been validated for the geometric elements: 3D Line, Plane, 3D Circle, Cylinder, Cone and Sphere.



Physikalisch-Technische Bundesanstalt  
National Metrology Institute

tag: Algorithm

# What's new

## Touch Probe Manager improvements

Ability to display the tools that locate the Calibration sphere.

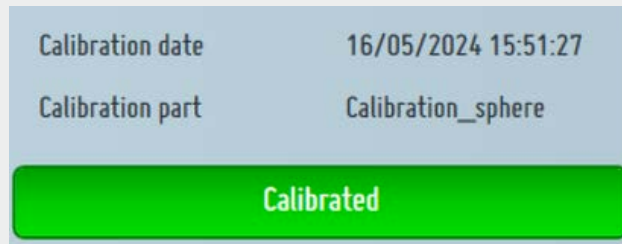

You can also know which probe has located the calibration parts.

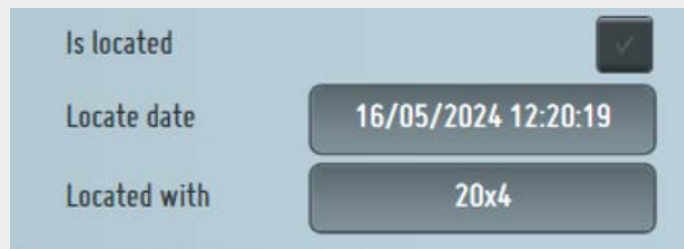

**tag:** Touch Probe Manager

## Graphical tips improvements for arms

New and improved representation of the graphical tips of the articulated arms.

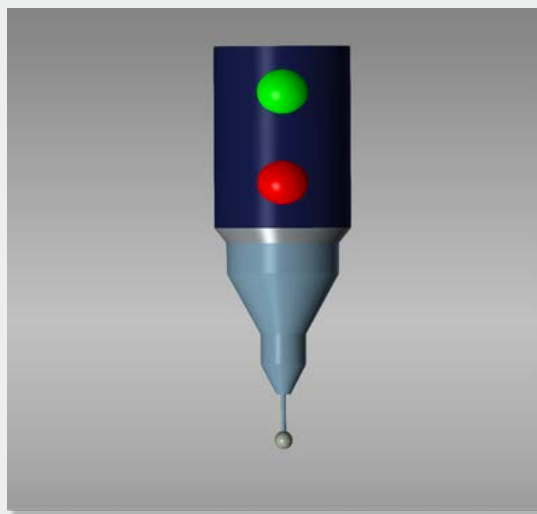

**tag:** Probe arms

**what we have  
improved**



# What we have improved

---

- **TD-I55** - Added "Import CAD" on Block program view
- **TD-I76** - Using a Fixed head, the calibration matrix will not appear
- **TD-I120** – TTP mode – Added Disk calibration in TTP mode.
- **TD-I201** – Pre-fill export session name with Project name
- **TD-I968** – Error map activation
- **TD-I1206** – PMT arm integration
- **TD-I1126** – Added Renishaw Equator as controller type
- **TD-I1127** – Head handling with Equator – In Machine Setup, when Renishaw Equator is selected, only "Equator" appears as Head type
- **TD-I1128** – Equator machine model – Now it is possible to select Renishaw Equator as CMM model
- **TD-I1211** – Auto-selection of the tool for a specific feature or feature point
- **TD-I1250** – Geometric compensation file selection – Added the option to select the geometric compensation file. It should be AC0 and AC1 and the default folder is C:\NMS\TouchDMIS\Settings\CalibData
- **TD-I1254** – Added Renishaw Equator for Master or Measure status
- **TD-I1270** – Tool Changer assembly dialog
- **TD-I1275** – Graphical Simulator – Added simulation speed and random error panel
- **TD-I1277** – Tool changer component selection delete button
- **TD-I1285** – SP25 scanning with Deva CNC
- **TD-I1286** – Graphical Simulator – UI panel for manual measurement
- **TD-I1288** – Tool changer button
- **TD-I1291** – Improved UI/UX in the Rack changer configuration page
- **TD-I1295** – Clearance – Docking offset for rack port
- **TD-I1294** – When a subassembly is added, all probes with the same subassembly will be specified
- **TD-I1298** – Added movement combo box in changer rack edit
- **TD-I1299** – Added A and B angles for each docking port in the Changer rack creation

- **TD-I1311** – Added Changer rack definition position
- **TD-I1322** – Added nominal probe to measured feature in the report
- **TD-I1327** – Error during the creation of L tool probe
- **TD-I1331** – Changed the default Changer rack approach and return
- **TD-I1334** – Added the possibility to hide/show a tooltip for features element
- **TD-I1353** – New DISTB algorithm
- **TD-I1361** – In Star probe creation remove the check if it is not selected
- **TD-I1364** – 3-2-1 Alignment – If “Obtain nominal” is checked, the textbox is disabled and shows the nominal value
- **TD-I1370** – Calibration after localization will be performed only if the tool is a nominal one
- **TD-I1371** - New incremental GoTo panel
- **TD-I1372** - Implementation of the Jump alignment (“Leap frog”)
- **TD-I1375** – Moved thermal compensation panel from settings to Measuring port
- **TD-I1377** - Improved Machine setup UI
- **TD-I1392** - Gear measurement implementation using external evaluation
- **TD-I1393** - New hotkey implementation (F5 = Program Play, F4 = Program Stop, F8 = Execution Step-by-Step)
- **TD-I1417** - TESA Reflex retrofit kit integration
- **TD-I1418** - Message in report when a nominal probe is used to measure a feature
- **TD-I1421** - Automation process interaction
- **TD-I1422** - Thermal compensation for CMM and Part
- **TD-I1423** - Calibration routine changes
- **TD-I1427** - Changes in the DMIS editor
- **TD-I1428** - API tracker V-Probe Integration
- **TD-I1429** - New protected Error map
- **TD-I1430** - New 5.0 Plugin functionality
-

**fixed bugs**



# Fixed bugs

---

- **TD-I117** – CAD is synchronized even when the Equate button is off
- **TD-I20** – Calibration map with PH6M fixed head
- **TD-I21** – Error during path editing using arc features
- **TD-I45** – Play button in DMIS does not continue after the breakpoint
- **TD-I48** – Error during password generation in the edit user window
- **TD-I73** – Orientation window message while using Fixed head
- **TD-I89** - Wrong cone location components
- **TD-I96** – No preview representation of cylinder with negative length
- **TD-I107** – Wrong formatting in the calibration textbox
- **TD-I108** – Error while selecting the single tip of a Star probe
- **TD-I116** – In machine setup, using CC3, “Obtain limits from controller” does not work
- **TD-I129** – Impossible to select some functionalities
- **TD-I316** – NMC300 – Wrong MCS GOTO’s after the saving of the calibration program
- **TD-I134** – Wrong tolerance output in DMIS editor
- **TD-I138** – Excel report – True position tolerance
- **TD-I152** – Wrong decimal separator in the deviation histogram
- **TD-I162** – After the Probe change the I++ Server does not update the TOOL parameters
- **TD-I164** – UCCserver – Error in the part program using LOOP statements
- **TD-I184** – Obtain nominal is not updated when the feature is selected
- **TD-I193** – CMM graphical representation error when loading a session
- **TD-I196** – Missing error tooltips in Assembly editor in case of multiprobe
- **TD-I204** – During the execution of the DMIS in step-by-step mode, PLAY button seems to be pressed
- **TD-I256** – The tree checkbox does not work
- **TD-I269** – Wrong translation in the Block program window
- **TD-I282** – Unrelated user data displayed after the creation of a new user
-

- **TD-I297** – User Interface got frozen during the execution of the part program
- **TD-I299** – Error while moving in Machine coordinate system
- **TD-I328** – Profile – The export in STEP or IGES is not compatible with Solidworks
- **TD-I370** - Crash on GEOM definition
- **TD-I414** – Wrong decimal separator in the tolerance values
- **TD-I461** – Wrong CAD layers behavior after “Save CAD as...”
- **TD-I803** – DMIS template wrong mm-to-inch conversion
- **TD-I934** – I++ TTP – During the Probe definition, it is not possible to set styli length less than 0.5mm
- **TD-I1010** – Difference between offline and online calibration program
- **TD-I1033** – Wrong formatting on the textual report
- **TD-I1058** – On CC3/2 with C3 wireless sensor always says that compensation is NOT active even if the sensor reads.
- **TD-I1133** - Measuring a circle with a star probe in MAN mode, the probe confirmation window appears before taking points with the previous probe
- **TD-I1189** – In the graphic form error the negative zone of the points is not represented
- **TD-I1191** – SP25 – After a long scanning the CMM switches to trigger mode
- **TD-I1193** – SP25 with NMC300 controller – Scanning of a circle does not start at the center of the ruby ball
- **TD-I1194** – SP25 with NMC300 controller - Cannot set scan speed during tools calibration
- **TD-I1195** – Error in the creation of the scan points using LK controllers
- **TD-I1198** – Wrong calibration value after the localization of another calibration sphere
- **TD-I1201** – Depth on scanning
- **TD-I1202** – TP20 Star probe with NMC300 controller – During the calibration the Tool does not change
- **TD-I1203** – Selecting TP20 with star probe using NMC300 controller CMM doesn't move
- **TD-I1205** – CONST/TR points compensation error
-

- **TD-I1208** – Manual calibration button does not work
- **TD-I1209** – Poorly calibration using the Recalibrate option
- **TD-I1212** – Excel output – Using the imperial system, Excel output will be in mm
- **TD-I1222** – Activator Defining Workspace – When clicking on "Define workspace" in the activator the max and min values need to be deleted so that values are updated. If the values are bigger than the CMM volume, they are not updated
- **TD-I1223** – CAD View – Missing the keep original file option
- **TD-I1224** – CAD View – Even when selecting "No" to changes in the CAD model, TouchDMIS keeps the editing
- **TD-I1229** – Error in Automation Safety Zone / GoHome position using I++
- **TD-I1232** – Wrong cylinder passing through two circles and a surface
- **TD-I1235** – Distance out of tolerance error is always positive in the report
- **TD-I1239** – PH10 position loss when TouchDMIS is closed
- **TD-I1240** – UCCserver – Sphere locate does not update
- **TD-I1241** – At the end of calibration, the program remains in PROG mode
- **TD-I1243** – GoHome position error using a non-RefTool probe
- **TD-I1246** – Fatal error in parallelism construction
- **TD-I1251** – Equator – Reset Min and Max volume values – Reset Min and Max volume values before movements of Equator to obtain volume values
- **TD-I1252** – Renishaw Equator Head rotation volume message error
- **TD-I1259** – Create surface from plane features
- **TD-I1263** – In Block window view, the first measured element does not appear
- **TD-I1265** – Error in XML file using a feature output with two different reference systems
- **TD-I1267** – Not able to change language in real-time
- **TD-I1269** – When an existing stylus is redefined TouchDMIS gives an error
- **TD-I1300** – PCS field name does not allow more than ten characters/numbers
- **TD-I1303** - Parallelism between two measured lines returns an infinite value
- **TD-I1307** – The geometrical compensation inside the controller is not available
- **TD-I1308** – The probe is not written in the program
- **TD-I1310** – I++ Server – The Machine does not move after translation alignment
-

- **TD-I1314** – NMC300 – Fixed calibration movement and position
- **TD-I1325** – Graphical Simulator manual point window shown in the calibration window
- **TD-I1326** – Removed “Last component from assembly” active after the first Probe assembly
- **TD-I1327** – L shape tool creation is wrong
- **TD-I1328** – Report – The labels point to the Ruby center instead of the nominal point
- **TD-I1332** – Manual measure panel is shown even if not using the Graphical simulator
- **TD-I1335** – Wrong Z negative alignment using UCCserver
- **TD-I1337** – Wrong Star probe graphical representation
- **TD-I1368** – Cannot define FA( ) slot
- **TD-I1342** – Report – The anchors point to the actual value instead of the nominal one
- **TD-I1350** - Enter button does not work on numerical input
- **TD-I1351** – Cannot construct point from curve
- **TD-I1352** – Removed TOL keyword from DECPL
- **TD-I1354** – Missing hierarchical panel translation
- **TD-I1355** – Wrong formatting in Tabulated reporting using different languages
- **TD-I1358** – Wrong point compensation in surface construction
- **TD-I1359** – The 3D position tolerance applied to a point is wrong
- **TD-I1360** – Unable to measure Cone in 5-axes
- **TD-I1374** – Error during TXT output
- **TD-I1379** – NMC300 - Wrong rotation during manual calibration
- **TD-I1380** – Not requested recalibration during the locate of the calibration sphere
- **TD-I1381** – Error in the automatic localization procedure
- **TD-I1386** – Arms and Trackers: fixed missing geometrical compensation
- **TD-I1391** – Error with new calibration after deleting all tool positions
- **TD-I1431** – Star probe wrong position
- **TD-I1436** – Missing calibration part info in Calibration status window
- **TD-I1438** – Calibration part missing in “Located with”
-

# supported hardware & drivers



# Supported Hardware & Drivers

## System Firmware/driver/software version

<b>UCC 2-2, T3, T5, S3, S5</b>	UCCserver 5.9.x
<b>Pantec</b>	Available
<b>CC3</b>	V.3.87
<b>DEVA 004</b>	Devacmmctrl61
<b>AX3 (unit for man. CMMs)</b>	AX3_V4ND_4.10
<b>HEXAGON ARMS</b>	Infinite arm RDS 4.x, Absolute arm RDS 5.x
<b>FARO arms: Platinum, Edge</b>	Faro arm Driver Bundle 6.6.0.15
<b>DEVA MANUAL (DEVA 001 + DEVA 0037)</b>	Devacmmctrl61
<b>LK MCC NMC</b>	Firmware nmc300_35
<b>GRAPHICAL SIMULATOR</b>	Available
<b>API laser tracker: Radian, OTII</b>	SDK RadianPlus-OmniTrackII 5.17.6 (Radian Pro 4.24.16.1)
<b>RD77</b>	Available
<b>IMUSB-100 MH</b>	Release January 2018
<b>PMT arms</b>	3.0.5.1E

# PC specifications

# PC Specifications

## Minumum (manual CMM, small CAD models)

<b>OS</b>	64-bit Windows 10
<b>CPU</b>	Intel Core i5
<b>RAM</b>	8 GB
<b>HARD DRIVE</b>	256 GB SSD
<b>GRAPHICS</b>	2 GB NVIDIA chipset supporting DirectX 11 or higher, feature level 11
<b>USB</b>	2, USB 2.0 - 3.0 (TouchDMIS license key and CMM communication)
<b>MICROSOFT .NET</b>	4.7.2
<b>ETHERNET</b>	1, 100 Base-T Ethernet port (CMM controller)

## Reccomended (CNC, CMM using CAD or a laser scanner)

<b>OS</b>	64-bit Windows 10, Professional
<b>CPU</b>	Intel Core i7
<b>RAM</b>	16 GB
<b>HARD DRIVE</b>	1 TB SSD
<b>GRAPHICS</b>	4 GB NVIDIA chipset supporting DirectX 11 or Higher, feature level 12
<b>USB</b>	1, USB 2.0 (TouchDMIS license key) or 1 USB (or serial RS232) for systems with PH10 controller
<b>MICROSOFT .NET</b>	4.7.2
<b>ETHERNET</b>	1, 100 Base-T Ethernet port (CMM controller)

Copyright 2024 © CIM Solutions Srl

All right reserved.

The information in this document is subject to change without prior notice and is intended as general information only.

# TouchDMIS

THE MEASURING TOUCH



s.o.l.u.t.i.o.n.s

Pre-Release v. May 2024